

# itC *IP NETWORK PA SYSTEM*



Please follow the instructions in this manual to obtain the optimum results from this unit. We also recommend that you keep this manual handy for future reference.

## TABLE OF CONTENTS

1. SAFETY PRECAUTIONS.....	3
2. APPLICATION.....	5
3. FEATURES.....	5
4. NOMENCLATURE AND FUNCTIONS.....	6
5. TERMINAL CONFIGURATION OPERATING INSTRUCTIONS.....	7
6. OPERATION .....	10
7. BLOCK DIAGRAM.....	11
8. SPECIFICATIONS.....	12
9. INSTALLATION METHOD.....	13

# 1. SAFETY PRECAUTIONS

- Be sure to read the instructions in this section carefully before use.
- Make sure to observe the instructions in this manual as the conventions of safety symbols and messages regarded as very important precautions are included.
- We also recommend you keep this instruction manual handy for future reference.

## Safety Symbol and Message Conventions

Safety symbols and messages described below are used in this manual to prevent bodily injury and property damage which could result from mishandling. Before operating your product, read this manual first and understand the safety symbols and messages so you are thoroughly aware of the potential safety



### WARNING

Indicates a potentially hazardous situation which, if mishandled, could result in death or serious personal injury.



### CAUTION

Indicates a potentially hazardous situation which, if mishandled, could result in moderate or minor personal injury, and/or property damage.



### WARNING

#### When Installing the Unit

- Do not expose the unit to rain or an environment where it may be splashed by water or other liquids, as doing so may result in fire or electric shock.
- Use the unit only with the voltage specified on the unit. Using a voltage higher than that which is specified may result in fire or electric shock.
- Do not cut, kink, otherwise damage nor modify the power supply cord. In addition, avoid using the power cord in close proximity to heaters, and never place heavy objects -- including the unit itself -- on the power cord, as doing so may result in fire or electric shock.
- Be sure to replace the unit's terminal cover after connection completion. Because high voltage is applied to the speaker terminals, never touch these terminals to avoid electric shock.
- Be sure to ground to the safety ground (earth) terminal to avoid electric shock. Never ground to a gas pipe as a catastrophic disaster may result.
- Avoid installing or mounting the unit in unstable locations, such as on a rickety table or a slanted surface. Doing so may result in the unit falling down, causing personal injury and/or property damage.

#### When the Unit is in Use

- Should the following irregularity be found during use, immediately switch off the power, disconnect the power supply plug from the AC outlet and contact your nearest **ITC** dealer. Make no further attempt to operate the unit in this condition as this may cause fire or electric shock.
  - If you detect smoke or a strange smell coming from the unit.
  - If water or any metallic object gets into the unit
  - If the unit falls, or the unit case breaks
  - If the power supply cord is damaged (exposure of the core, disconnection, etc.)
  - If it is malfunctioning (no tone sounds.)
- To prevent a fire or electric shock, never open nor remove the unit case as there are high voltage components inside the unit. Refer all servicing to your nearest **ITC** dealer.
- Do not place cups, bowls, or other containers of liquid or metallic objects on top of the unit. If they accidentally spill into the unit, this may cause a fire or electric shock.
- Do not insert nor drop metallic objects or flammable materials in the ventilation slots of the unit's cover, as this may result in fire or electric shock.

### CAUTION

#### When Installing the Unit

- Never plug in nor remove the power supply plug with wet hands, as doing so may cause electric shock.
- When unplugging the power supply cord, be sure to grasp the power supply plug; never pull on the cord itself. Operating the unit with a damaged power supply cord may cause a fire or electric shock.
- When moving the unit, be sure to remove its power supply cord from the wall outlet. Moving the unit with the power cord connected to the outlet may cause damage to the power cord, resulting in fire or electric shock. When removing the power cord, be sure to hold its plug to pull.
- Do not block the ventilation slots in the unit's cover. Doing so may cause heat to build up inside the unit and result in fire.
- Avoid installing the unit in humid or dusty locations, in locations exposed to the direct sunlight, near the heaters, or in locations generating sooty smoke or steam as doing otherwise may result in fire or electric shock.

#### When the Unit is in Use

- Do not place heavy objects on the unit as this may cause it to fall or break which may result in personal injury and/or property damage. In addition, the object itself may fall off and cause injury and/or damage.
- Make sure that the volume control is set to minimum position before power is switched on. Loud noise produced at high volume when power is switched on can impair hearing.
- Do not operate the unit for an extended period of time with the sound distorting. This is an indication of a malfunction, which in turn can cause heat to generate and result in a fire.
- Contact your **ITC** dealer as to the cleaning. If dust is allowed to accumulate in the unit over a long period of time, a fire or damage to the unit may result.
- If dust accumulates on the power supply plug or in the wall AC outlet, a fire may result. Clean it periodically. In addition, insert the plug in the wall outlet securely.
- Switch off the power, and unplug the power supply plug from the AC outlet for safety purposes when cleaning or leaving the unit unused for 10 days or more. Doing otherwise may cause a fire or electric shock.

An all-pole mains switch with a contact separation of at least 3 mm in each pole shall be incorporated in the electrical installation of the building.

## 2. APPLICATION

Professional outdoor one-key-for-help network intercom terminal is designed for safe city, large parks, tunnels, mines and other places. It can also be used to broadcast and play background music.

## 3. FEATURES

1. All-metal shell piano paint technology, with anti-explosion and waterproof shell, it's durable and can be fixed in the outdoor vertical bar or wall mounted.
  2. Equipment adopts embedded computer technology and DSP audio processing technology design; with high-speed industrial-grade chip, the start time is less than 1s.
  3. Built-in 1 channel network hardware audio decoding module, support TCP/IP, UDP, IGMP (multicast) protocol, to achieve the network transmission 16-bit CD audio quality audio signal.
  4. Built-in voice intercom call module, support full-duplex voice intercom and call, with high-performance DSP audio processing, support for digital echo cancellation and audio compression function.
  5. Built-in 5W high-fidelity full-range speakers, clear and loud call sound; built-in 30W digital constant-resistance power amplifier, can externally connect to constant-resistance speakers, which is suitable for outdoor PA needs.
  6. Built-in high-sensitivity microphone, support hands-free calls, support custom answer, wide voice collection area & high sound reproduction.
  7. Built-in monitoring function, support service-level recording management, built-in audio signal line output, can connect with monitoring system.
  8. With 1 channel short circuit input and 1 channel short circuit output, short circuit input is for linkage signal data acquisition in places like tunnel; short circuit output is for safe city monitoring video linkage.
  9. With energy-saving management switch, when no broadcasting or help, the digital amplifier power supply is turned off and enable energy-saving mode.
  10. One channel DC 24V power output for external alarm equipment to provide power supply.
  11. Support custom targets calling, support one-button call, one key for help.
  12. Support a variety of call strategies, including call forwarding, no answer reminder.
  13. Support transfer time and custom ring time.
  14. Support program library quick playing presetting, support network remote trigger program broadcasting.
  15. Support custom hang mode, optional active or passive hang mode.
  16. Design of high protection degree (IP55), the overall use steel shell and anti-removable screws, can be anti-explosion, waterproof, anti-acupuncture.
  17. Support router, switch, bridge gateway, Modem, Internet, 2G, 3G, 4G, multicast, unicast and random network structure.
  18. Digital products, easy to expand, not subject to geographical restrictions, no need to add management equipment in engine room, use the design concept of total network free line construction, easy to install.
- \* 24V DC power supply can be customized, to meet the needs of outdoor solar battery power supply.

## 4. NAME AND FUNCTION OF PARTS

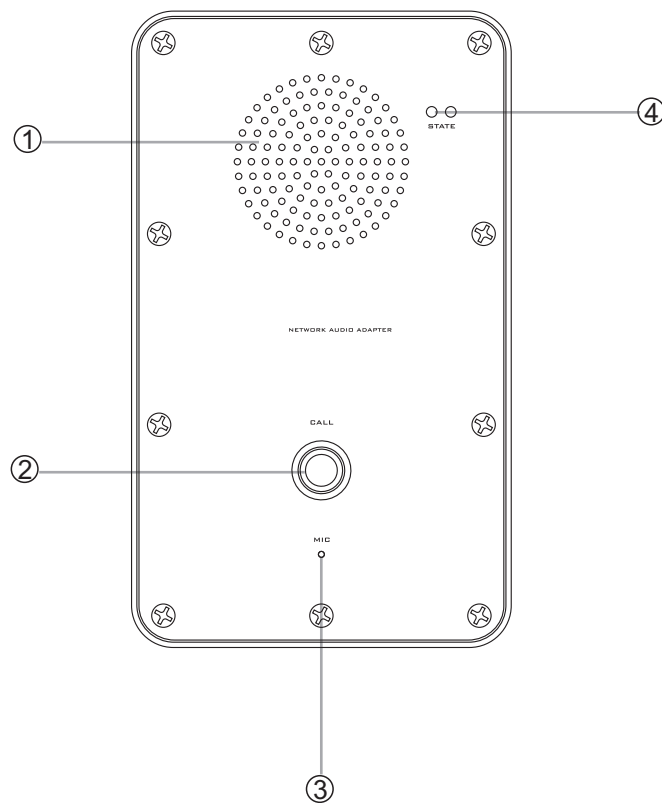

1. Monitoring speaker is used for the audio sign output of the call center
2. Call button, press the button, the machine turn into the emergency call state for calling; and then press the button again to cancel the emergency call state;
3. Intercom microphone; when the machine is in the intercom state, speak towards it; the distance between the source and the hole can't exceed 60cm (no obstacle in the middle).
4. Working status indicator light.

## 5. TERMINAL CONFIGURATION OPERATING INSTRUCTIONS

The terminal needs to be configured before installation, before installation, need make a installation plan including terminal name, terminal IP address, gateway IP address, server IP address, location of terminal installation, and label the information on the terminal to ensure the convenient use of the device. Please save the plan as an electronic document for future maintenance. After the system planning is completed, please configure parameters of each terminal includes “terminal IP address, subnet mask, gateway and server address”.

1. Installing software. Find the IP network broadcast system software installation package, double-click to open it, click on the program “terminal configuration tool”, after the installation of the program is completed, as shown below:

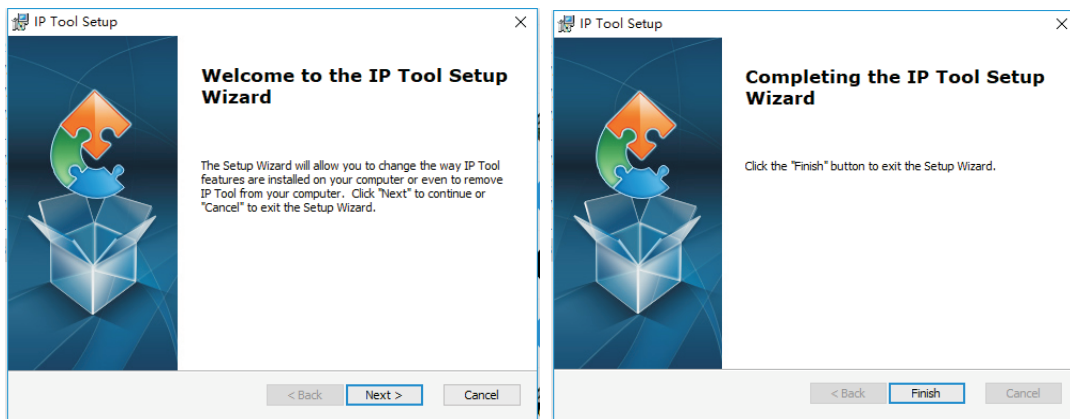

2. After the program is installed, a icon is generated on the desktop, as shown below:



3. Double-click the icon to run, and the “terminal configuration tool” window will pop up, as shown below:

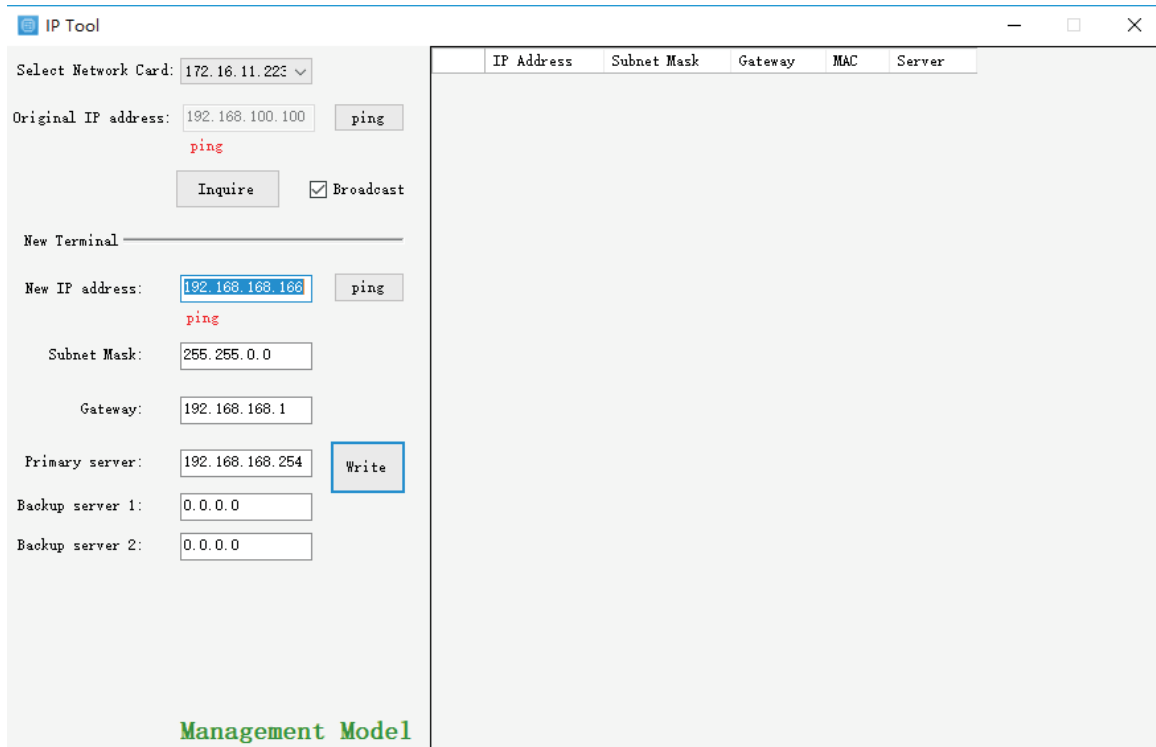

## 5. TERMINAL CONFIGURATION OPERATING INSTRUCTIONS

The configuration steps:

Step 1: Connect the terminal and the computer installed with the terminal configuration tool program by the network wire, Plug in the power until the terminal power indicator is on.

Step 2: double-click to open the shortcut icon of “ terminal configuration tool”, select the network card first, and left-click the “query” button in the window, to query the terminal’s original IP address. Please pay attention to: local IP address of the computer should be set in the same network segment as the terminal, because the default IP of terminal is : 192.168.168.166, so the computer’s local IP address should also be set to: 192.168.168.X, otherwise it maybe not match the IP terminal address.

Step 3: In the window of “Terminal Configuration Tool” , fill in correct “IP address”, “Subnet mask”, “Gateway IP” and “Server IP”, as below :

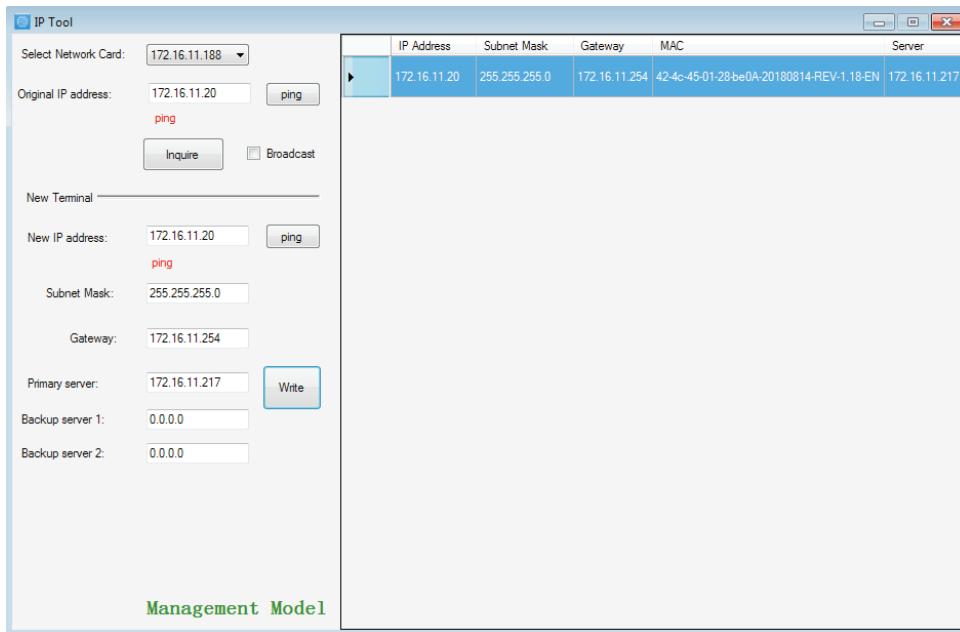

Step 4: left click on the “write” button, there will be a window prompt after the successful configuration; after that, left click on the “query” button, the parameters of the terminal will be re-read by the configuration program, if it display as the same as entered one, means that the configuration was successful.

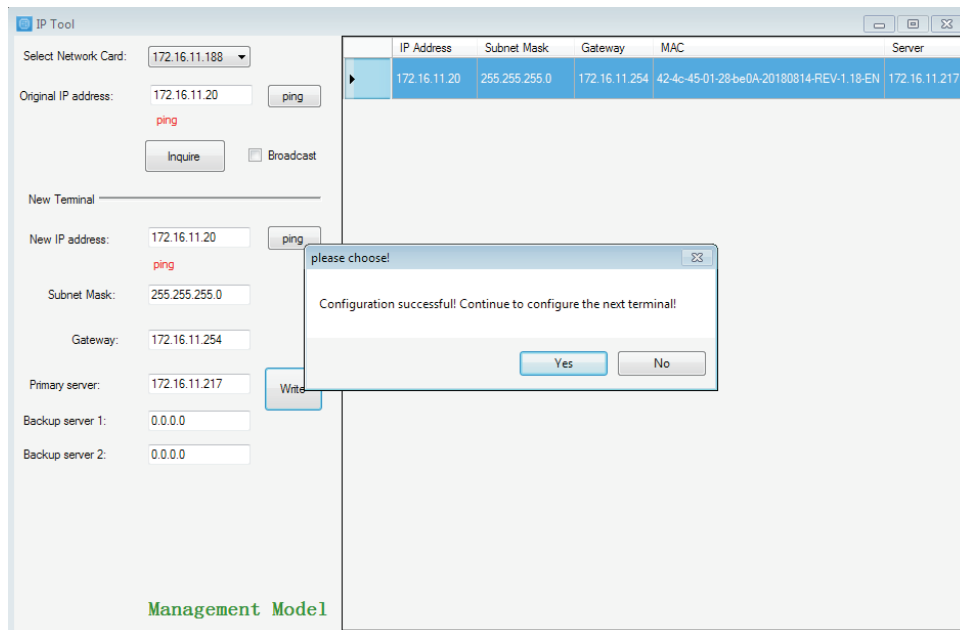



## 5. TERMINAL CONFIGURATION OPERATING INSTRUCTIONS

Step 5: If multiple terminals are in the same network segment, you only need to modify the IP address of one terminal, it is needed to click on the terminal in the queried terminals list, then cancel the choice of broadcast on the left interface, modify the IP address and click for configuration.

The IP Tool interface consists of a configuration panel on the left and a table of terminal data on the right. The configuration panel includes fields for network card selection, original and new IP addresses, subnet mask, gateway, primary and backup servers, and a 'Write' button. A 'Broadcast' checkbox is also present. The table lists terminals with columns for IP Address, Subnet Mask, Gateway, MAC, and Server. In the top screenshot, the terminal with IP 172.16.11.20 is selected. In the bottom screenshot, the terminal with IP 172.16.11.34 is selected, and a success message is displayed.

Notes: If the terminal data can't be queried or the network is blocked, the pop-up window will say Reconfigure the IP address or IP address writing error. In this case, please reconfigure the network, check the network cable, and turn off the firewall, etc.

## 6. OPERATION

Instructions:

1. Before connecting the power supply, check whether the local power grid matches the power supply specified in the manual or not.
2. Complete IP address code settings of terminal according to the operation instruction by using cable;
3. Use 568B cable to connect the control host (PC);
4. Working indicator light specific status show as follows:
  - ① Idle, red and green alternately on, 1.0 seconds interval;
  - ② Emergency help, green light on, red light off;
  - ③ Answer/call waiting, green light flash slowly, 1.0 seconds interval;
  - ④ Environmental monitoring, red light flash slowly, 1.0 seconds interval;
  - ⑤ Network failure, red light flash quickly, 0.2 seconds interval.
5. Press the help button on panel, after getting through the help center, close to the microphone for speaking, you can talk with the help center instantly.

### ● Prompt

Default terminal IP address: 192.168.168.168

Subnet mask: 255.255.0.0

Gateway: 0.0.0.0

Server IP: 192.168.168.254

# 7. BLOCK DIAGRAM

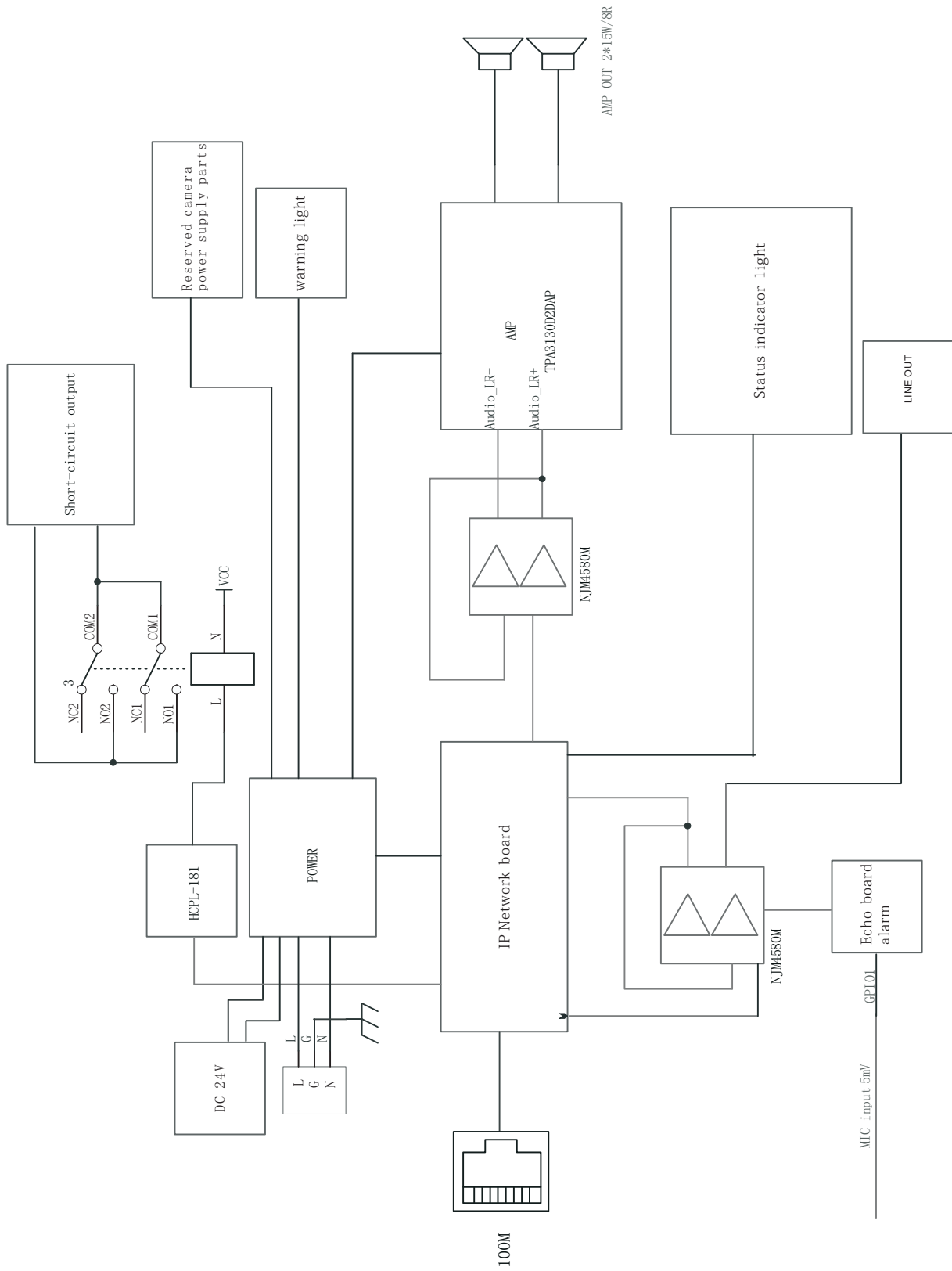

## 8. SPECIFICATIONS

Model	T-7732
Network Interface	Standard RJ45 input
Support protocol	TCP/IP, UDP, IGMP (Multicast)
Audio Format	MP3
Sampling Rate	8K~48KHz
Transmission rate	100Mbps
Audio mode	16 bit CD tone quality
THD	≤1%
Frequency response	80Hz~16KHz +1dB/-3dB
SNR	>65dB
Protection degree	IP55
Operation temperature	-20°C~+60°C
Operation humidity	20%~80% relative humidity without moisture condensation
Power Consumption	≤40W
Operating Voltage	~220V 50Hz
Dimensions	290×168×133mm
Weight	4.2Kg

## 9. INSTALLATION METHOD

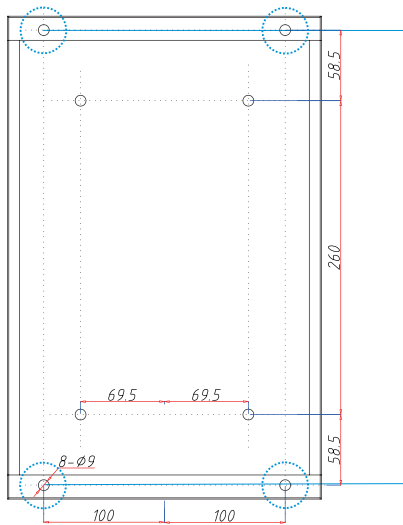

1. Make installation hole on wall. Put the terminal wall mount accessory at a proper height of the wall, and make 4 installation holes which distance size is 377\*200mm.

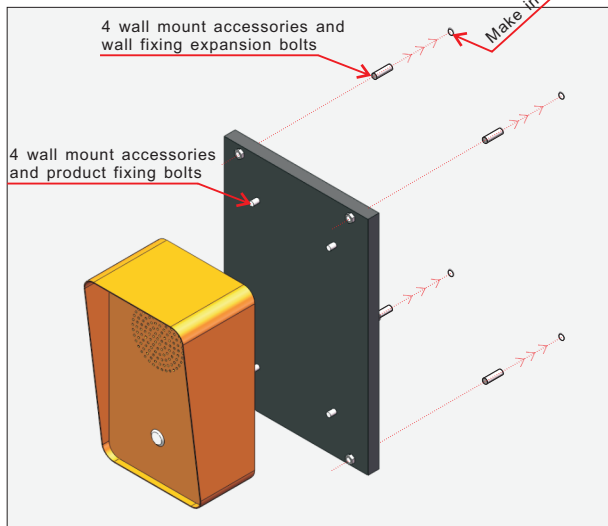

2. Fixing product. Place the expansion bolts into the wall openings, and fix the product with the four bolts to the wall mount accessories, then fix the wall accessories on the wall by the nuts of the expansion bolts.

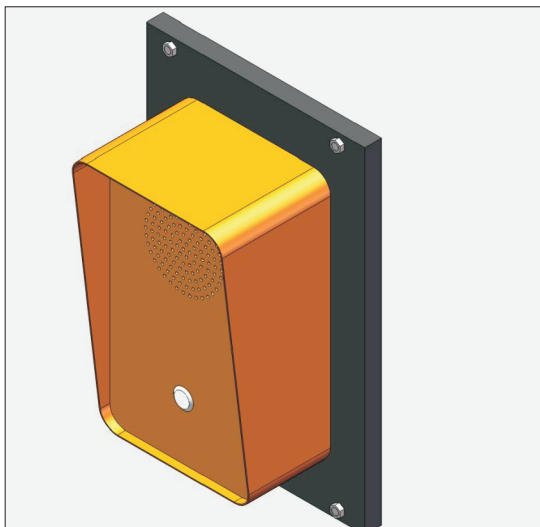

3. Installation finished.

# IP NETWORK PA SYSTEM

VersionV0.1

