

Mini UPS RC1 PS12338W

Mini UPS Product Specification Sheet

Mini UPS

1. Summary:

This is an on-line uninterruptible storage power supply. UPS interior adopts the safe and environmental 18650 lithium cells, DC-DC boost mould, the professional IC, smart charging BMS IC, they could be provided the trickle, constant-current, constant-voltage charging etc function. The ups could be automatically adjusts the charging current which based on the external adapter input voltage changeful. The DC output is 12V1A and 12V 1A, 5V USB output 5V 1A. The circuit adopts hardware and software etc multi-protective function steps, it has completed over-charged, over-discharged, over-current, short-circuit etc protective function.



Mini UPS RCI PS12338W

2. Main Spec:

● Feature

1. Small switching change, short transfer Time;
2. UPS max charging current is 0.8A, as automatically recognize the adapter charging ability, it based on voltage step-down to adjust the charging current;
3. Multi-output 5V 1A, 12V 1A and 12V 1A;
4. Circuit adopts the hardware、 software etc multi-protective function steps;
5. UPS has low capacity indicator、 adapter input indicator、 battery working indicator、 charging indicator;
6. UPS interior has prefer over-charged、 over-discharged、 over-current、 short-circuit etc multi-protective function.
7. Capacity: 38.48wh,4pcs 2600mAh、 volume size: 116*73*24cm、 Net weight: 248g.

● Function Diagram:

Mini UPS RCI PS12338W

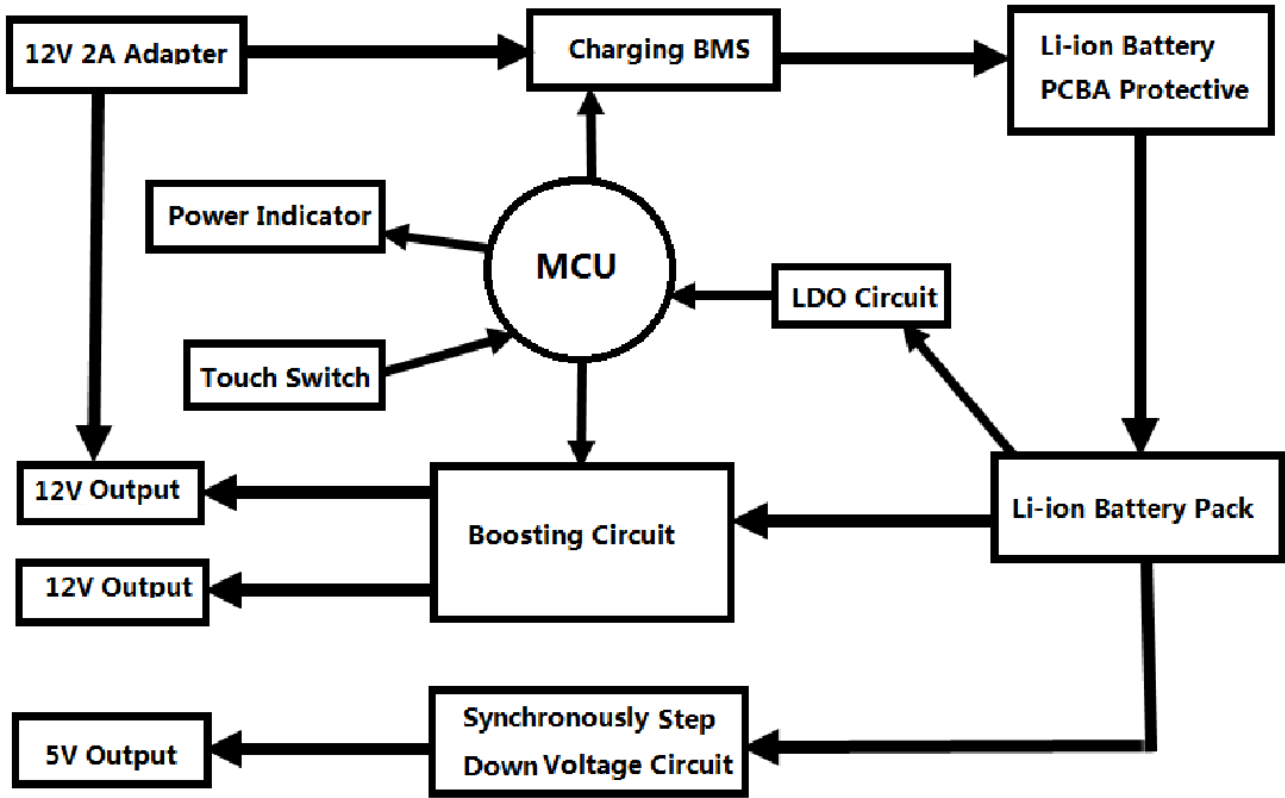

3. Electrical characteristics:

1. INPUT JACK FEATURE				
No.	Item	Mini Value	Standard	Max Value
1.1	Rated Input voltage	-	12V	-
1.2	Input Voltage Range	11.6V	12V	13V
1.3	Charging current	--	0.6A	0.8A
1.4	Discharging transfer efficiency	--	≥80%	--

Remark: When the input voltage less than 12V, the circuit will follow the voltage dropping to turn down the current; when the input voltage less than 11.4V, no input current anymore.

2. 5V OUTPUT JACK FEATURE				
No.	Item	Mini Value	Standard	Max Value
2.1	5V output jack voltage	4.6V	5V	5.3V
2.2	5V output jack current	-	0.8A	1A
2.3	5V output over-current and step down protective unit	-	1A	1.2A
2.4	5V Discharging transfer efficiency	-	88%	-

Mini UPS RCI PS12338W

3. 12V OUTPUT JACK FEATURE

3.1	12V output jack voltage	10.5V	12V	12.2V
3.2	12V output jack current	-	0.8A	1A
3.3	12V output over-current and step down protective unit	-	1A	1.2A
3.4	12V Discharging transfer efficiency	-	85%	-

4. 12V OUTPUT JACK FEATURE

4.1	12V output jack voltage	10.5V	12V	12.2V
4.2	12V output jack current	-	0.8A	1A
4.3	12V output over-current and step down protective unit	-	1A	1.2A
4.4	12V Discharging transfer efficiency	-	85%	-

4. Li-ion Battery with PCB characteristics:

Item 项目	Symbol 符号	Content 详细内容	Standard
Over Charged Protection 过充保护	V_{DET1}	Over charge detected voltage 过充电检测电压	4.30±0.025V
	tV_{DET1}	Over charge detection delay time 过充电检测延迟时间	500~1500ms
	V_{REL1}	Over charge release voltage 过充电解除电压	4.15±0.08V
Over discharge protection 过放保护	V_{DET2}	Over discharge detection voltage 过放电检测电压	2.7±0.2V
	tV_{DET2}	Over discharge detection delay time 过放电检测延迟时间	50~150ms
Over current protection 过流保护	V_{DET3}	Over current detection voltage 过电流检测电压	0.20±0.025V
	I_{DP}	Over current detection current 过电流保护电流	12A~20A
	tV_{DET3}	Detection delay time 检测延迟时间	5~15ms
		Release condition 保护解除条件	Cut load 断开负载

Mini UPS RC1 PS12338W

Short protection 短路保护		Detection condition 保护条件	Exterior short circuit 外部电路短路
	T_{SHORT}	Detection delay time 检测延迟时间	$\leq 12\mu s$
		Release condition 保护解除条件	Cut short circuit 断开短路电路
Interior resistance 内阻	R_{DS}	Main loop electrify resistance 主回路通态电阻	$V_C=3.7V$; $R_{DS}\leq 60m\Omega$
Current consumption 消耗电流	I_{DD}	Current consume in normal operation 工作时电路内部消耗	$I_{DD}\leq 30.0\mu A$

5. Touch Switch Indicate Feature:

No.	Item	Power Mode	Description
5.1	Touch Switch	---	<ul style="list-style-type: none"> - Double Click- switch on ups and indicator lighting up - Click once-switch off ups and indicator off
5.2	Discharging Indicator Status	Almost no power	LED twinkle 3 times, ups turns off
		$>25\%$	LED1 stay lighting, LED2,LED3 LED4 off
		25%~50%	LED1, LED2 stay lighting, LED3 and LED4 off
		50%~75%	LED1, LED2, LED3 stay lighting, LED4 off
		75%-100%	LED1, LED2, LED3, LED4 stay lighting,
5.3	Charging Indicator Status	$< 25\%$	LED1 to LED4 turns twinkle
		25%~50%	LED1 stay lighting, LED2 to LED4 turns twinkle
		50%~75%	LED1, LED2 stay lighting, LED3 to LED4 turns twinkle

Mini UPS RC1 PS12338W

		75%~99%	LED1, LED2, LED3 stay lighting, LED4 turns twinkle
		100%	LED1, LED2, LED3, LED4 stay lighting,

6. Applications:

This multi-output mini ups widely use for fingerprint attendance machine, Fire safety system, security monitoring system, wireless camera, CCTV camera ,personal treatment system, Door security system, personal data assistant, emergency lighting, Alarm system, personal communication systems, radio, digital cameras, camcorders, video camera, Bluetooth devices, CD players, MD players, portable DVD, MP3 players, smart cards.

Mini UPS Working Condition:

- Charging: 0°C~55°C
- Discharging: -20°C~65°C
- Storage 30days: -20°C~~45°C
- Storage 90days: -20°C~35°C
- Should store the mini UPS under the pleasantly cool and arid place if long time don't use it. Otherwise poor performance may occur due to the poor connection with the equipment.

Storage:

When stored, the UPS will self-discharge at a rate that is greatly affected by the ambient temperature. UPS should therefore be fully charged before being put into storage and if they are to be stored for a long period they should be recharged periodically to prevent them from losing their original capacity. As a guide, the UPS should not be stored for longer than the periods shown below without being recharged:

Mini UPS RCI PS12338W

- 6 months at 20°C
- 3 months at 30°C
- 2 months at 35°C
- If long time did not use this mini UPS, suggest to charge it once every 3~5months

Safety Warning:

- Do not expose the mini UPS in the rain or snow;
- Do not use or leave the mini UPS near a heating source as fire or heater;
- Do not connect the DC cable in wrong way;
- Do not use the wrong voltage adapter;
- Devices voltage must matching with the mini UPS voltage
- Please leave away this mini UPS from children