

## GEPON OLT Optical Module



### Product Features

- Compatible IEEE 802.3ah 1000BASE-PX20/PX20+ GEPON application
- Applied to EPON OLT for a Single Fiber Bi-directional EPON System
- SFP, Single SC connector, Digital Diagnostic Interface Compliant with SFF-8472
- Burst Digital Receiving Signal Strength Indication (RSSI)
- Single 3.3V power supply
- Operation case temperature -40~85°C for industrial and -10~70°C for commercial
- RoHS-6 compliance

### Absolute Maximum Ratings

Parameter	Unit	Min.	Typical	Max.
Power Supply	V	0		4.2
Storage Ambient Temperature	°C	-40		85
Operating Case Temperature	°C	-40		85
Operating Relative Humidity	%	5		95
Receiver Damaged Threshold	dBm	0		

### Operating Condition

Parameter	Unit	Min.	Typical	Max.
Power Supply	V	3.1	3.3	3.5
Operating Case Temp for C-temp	°C	-10		70
Operating Case Temp for I-temp	°C	-40		85
Operating Relative Humidity	%	5		95
Data Rate(TX/RX)	Gbit/s		1.25	

### Optical Characteristics

Parameter	Unit	Min.	Typ.	Max.
TX Central Wavelength	nm	1480		1500
Spectral Width (-20dB)	nm			1
SMSR	dB	30		
Mean Launched Power	dBm	2		7
Mean Launched Power (TX Off)	dBm			-39
Extinction Ratio(Note 1)	dB	9		
TX Total Jitter	UI			0.43
Rise/Fall Time (20%-80%)	ps			260
RIN <sub>15</sub> OMA	dB/Hz			-115
Optical Return Loss Tolerance	dB			12
Transmitter and dispersion Penalty(20km G.652)	dB			2.3
TX Optical Eye Mask	Compliant With IEEE Std 802.3ah™-2004			
Receive Wavelength	nm	1260		1360
Sensitivity (Note 2)	dBm			-30
Overload	dBm	-6		
Receiver Threshold Settling Time	ns			250
RX Dynamic Range(Note 3)	dBm	-30		-6
LOS-Deassert	dBm			-31
LOS-Assert	dBm	-45		
SD Hysteresis	dB	0.5		6
Receiver Reflectance	dB			-12

Note:

1. Measured with PRBS 2<sup>7</sup>-1 test pattern @1.25Gbps, Low Pass Filter is on.
2. Measured with a PRBS 2<sup>7</sup>-1 test pattern @1.25Gbps and ER=10dB, BER =10<sup>-12</sup>
3. RX Dynamic Range Definition

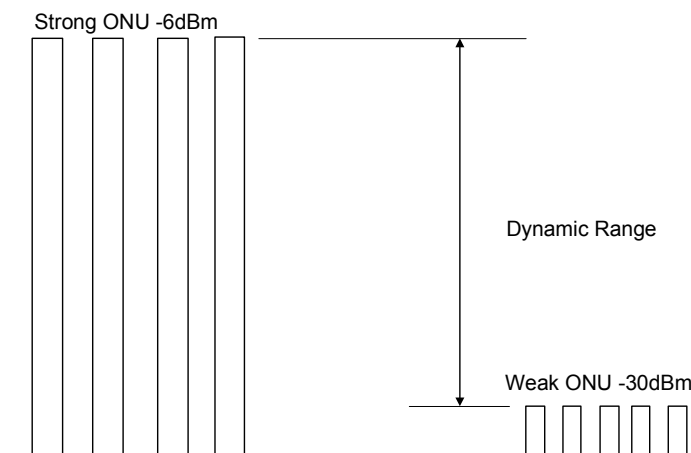

## Electrical Characteristics

Parameter	Unit	Min.	Typical	Max.
Power Supply Current	mA			300
Data Input Differential Swing	mV	200		1600
Data Differential Impedance	$\Omega$	90	100	110
TTL Input -Low	V	0		0.8
TTL Input -High	V	2.0		Vcc
TTL Output -Low	V	0		0.4
TTL Output -High	V	2.4		Vcc
Data Output Differential Swing	mV	400		1600
Los Assert Time	ns			500
Los Deassert Time	ns			500

## Pin Definition

Pin No.	Name	Level/Logic	Function	Description
1	GNDT	NA	Ground	Transmitter Ground
2	TX_Fault	LVTTTL	TX Fault	TX Fault Alarm, TX Fault State: High; TX Normal State: Low
3	TX_Dis	LVTTTL	Transmitter Enable/Disable	Active High
4	MOD-DEF2	LVTTTL	SDA	I2C clock
5	MOD-DEF1	LVTTTL	SCL	I2C data
6	MOD-DEF0	MOD-DEF0		Module Definition 0, Grounding in SFP
7	RSSI_Trig	LVTTTL	RSSI Trigger	Active High for Sampling
8	LOS	LVTTTL	Receiver Signal Detection	Loss of Signal. Asserted when light is off
9	GNDR	NA	Ground	Receiver Ground
10	GNDR	NA	Ground	Receiver Ground
11	GNDR	NA	Ground	Receiver Ground
12	RD-	LVPECL	Rx Data-	RX data NOT output, DC coupled output
13	RD+	LVPECL	Rx Data+	RX data output, DC coupled output
14	GNDR	GNDR	Ground	Receiver Ground
15	V <sub>cc</sub> R	NA	Receiver Power Supply	Rx Power
16	V <sub>cc</sub> T	NA	Transmitter Power Supply	Tx Power
17	GNDT	GNDT	Ground	Transmitter Ground
18	TD+	LVPECL	Tx Data+	TX data input, internally DC

				coupled with 100ohm terminated
19	TD-	LVPECL	Tx Data-	TX data NOT input, internally DC coupled with 100ohm terminated
20	GNDT	NA	Ground	Transmitter Ground

### Recommended Interface Circuit

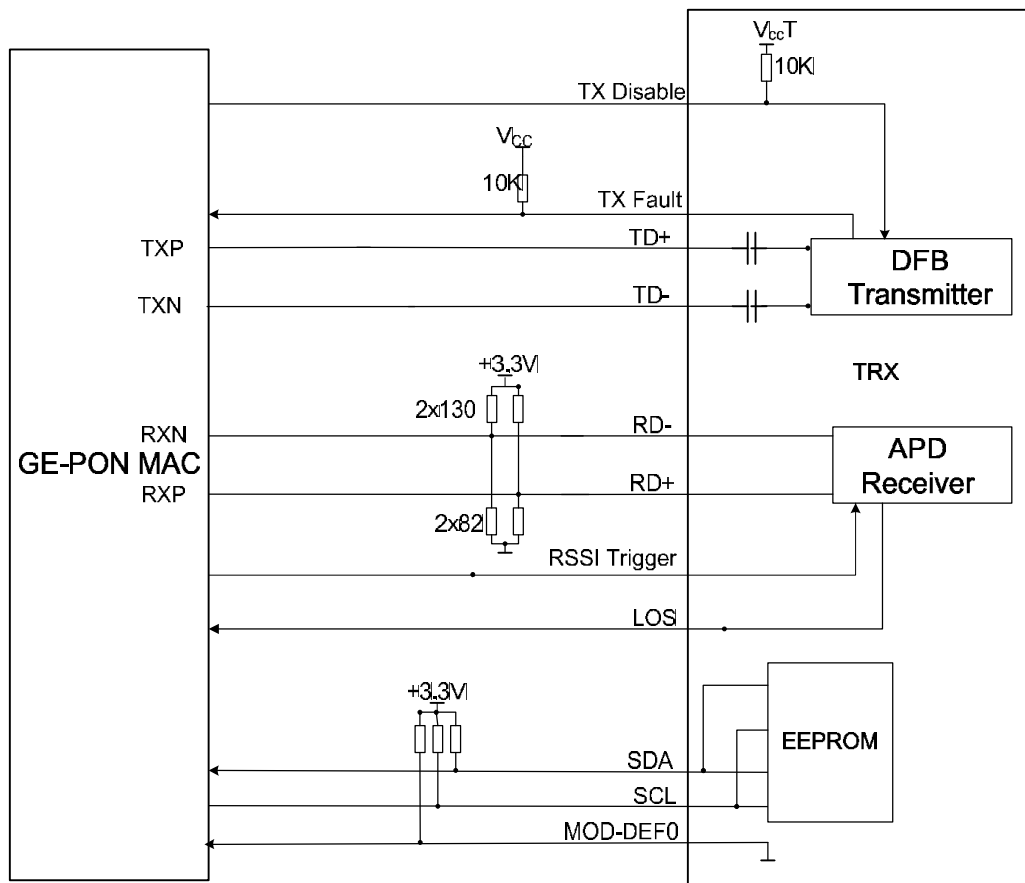

### RSSI Trigger Time Sequence

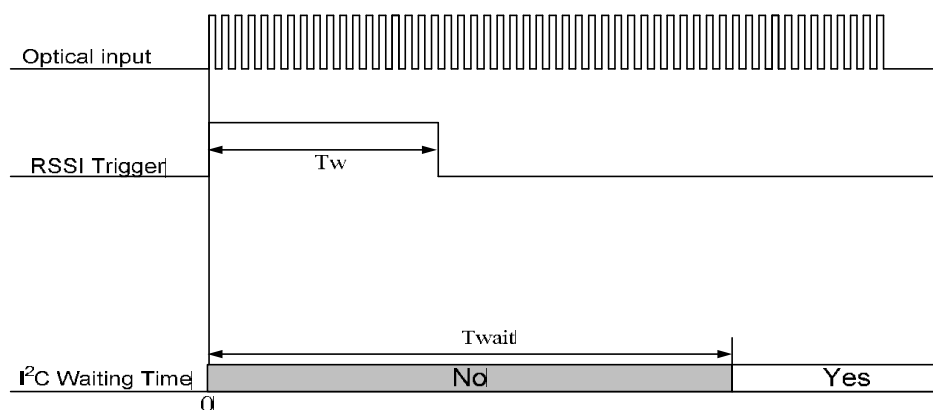

Item	Symbol	Min	Max	unit
Trigger width	$T_w$	1	1.25	us
I <sup>2</sup> C Waiting Time	$T_{wait}$		500	us

### Mechanical Diagram

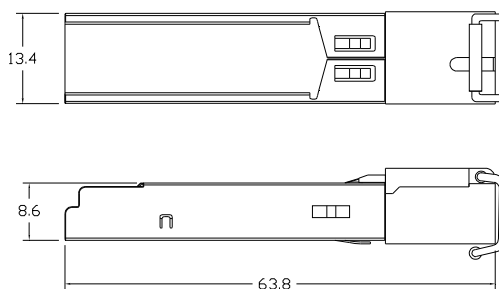

## EEPROM Information

### EEPROM Serial ID Memory Contents (A0h)

Addr.	Name	Hex	Description
0	Identifier	03	SFP transceiver
1	Ext. Identifier	04	
2	Connector	01	SC
3-10	Transceiver	00 00 00 00 00 00 00 00	BASE-PX
11	Encoding	01	8B10B
12	BR, Nominal	0D	1.25Gbps
13	Reserved	00	
14	Length (9um)-km	14	20(km)
15	Length (9um)	C8	200(100m)
16~18	Length	00 00 00	Not Support
19	Reserved	00	
20-35	Vendor name	xx xx	
36	Reserved	00	
37-39	Vendor OUI	00 00 00	
40-55	Vendor PN	xxxx	
56-59	Vendor Rev	xx xx 20 20	ASCII("30 31 20 20" means 0.1 Revision)
60-61	Wavelength	05 D2	1490nm Laser Wavelength
62	Reserved	00	
63	CC_BASE	xx	Check sum of byte 0-62
64-65	Options	00 1A	LOS, TX_FAULT and TX_DISABLE
66~67	BR, max BR, min	00 00	
68-83	Vendor SN	xx xx xx xx xx xx xx xx xx xx xx xx xx xx xx xx	ASCII
84-91	Date code	xx xx xx xx xx xx 20 20	Year(2 bytes), Month(2 bytes), Day(2 bytes)
92	Diagnostic Monitoring Type	68	Compliant with SFF-8472 V9.5 Internally Calibrated Received power measurement type -Average Power
93	Enhanced Options	B0	Soft TX_FAULT, Soft RX_LOS
94	SFF-8472 Compliance	02	Diagnostics Compliance(SFF-8472 V9.5)
95	CC_EXT		Check sum of byte 64-94
96-255	Vendor Specific		

**Digital Diagnostic Definition (A2h)**

<b>Data Address</b>	<b>Parameter</b>	<b>Range</b>	<b>Accuracy</b>
96-97	Temperature	-40 to +80°C	±3°C
98-99	Vcc Voltage	+2.9V to +3.6V	±3%
100-101	Bias Current	0 to 100mA	±10%
102-103	TX Power	0 to 8dBm	±3dB
104-105	RX Power	-32 to -5dBm	±3dB