



Applications

- 10G Ethernet
- 10G Fiber Channel

Product Features

- Optical interface compliant to IEEE 802.3ae 10GBASE-LR
- Electrical interface compliant to SFF-8431
- Digital Diagnostic Monitor Interface
- Hot pluggable
- 1310nm DFB transmitter, PIN photo-detector
- Applicable for 20km SMF connection
- High transmission margin
- Low power consumption
- Cost effective SFP+ solution, enables higher port densities and greater bandwidth
- Operating case temperature: 0 to 70 °C

General

SFP+-10G-LR - transceiver is designed to transmit and receive optical data over single mode optical fiber for link length 20km.

The transceiver designs are optimized for high performance and cost effective to supply customers the best solutions for telecommunication.

Absolute Maximum Ratings

Parameter	Symbol	Min.	Max.	Unit	Note
Supply Voltage	Vcc	-0.5	4.0	V	
Storage Temperature	Ts	-40	85	°C	
Relative Humidity	RH	0	85	%	

Note: Stress in excess of the maximum absolute ratings can cause permanent damage to the transceiver

General Operating Characteristics

Parameter		Symbol	Min.	Typ	Max.	Unit	Note
Data Rate	Ethernet			10.3125		Gb/s	
	Fiber Channel			10.518			
Supply Voltage		Vcc	3.13	3.3	3.47	V	
		Vcc				V	
Supply Current		Icc5			300	mA	
		Icc3				mA	
Operating Case Temp.		Tc	0		70	°C	

Electrical Input / Output Characteristics

Parameter		Symbol	Min.	Typ	Max.	Unit	Note
Transmitter							
Diff. input voltage swing			120		820	mVpp	1
Tx Disable input	H	VIH	2.0		Vcc+0.3	V	
	L	VIL	0		0.8		
Tx Fault output	H	VOH	2.0		Vcc+0.3	V	2
	L	VOL	0		0.8		
Input Diff. Impedance		Zin		100		Ω	
Receiver							
Diff. output voltage swing			340	650	800	mVpp	3
Rx LOS Output	H	VOH	2.0		Vcc+0.3	V	2
	L	VOL	0		0.8		

Note 1) TD+/- are internally AC coupled with 100Ω differential termination inside the module.

Note 2) Tx Fault and Rx LOS are open collector outputs, which should be pulled up with 4.7k to 10kΩ resistors on the host board. Pull up voltage between 2.0V and Vcc+0.3V.

Note 3) RD+/- outputs are internally AC coupled, and should be terminated with 100Ω (differential) at the user SERDES.

Optical Characteristics

Parameter	Sym bol	Min.	Typ	Max.	Unit	Note
Transmitter						
Operating Wavelength		1290		1330	nm	
Ave. output power (Enabled)	Po	-6		0	dBm	1
Extinction Ratio	ER	4			dB	1
RMS spectral width	$\Delta\lambda$			1	nm	
Rise/Fall time (20%~80%)	Tr/Tf			50	ps	2
SMSR				>30	dB	
Tx jitter(4m-80MHz)				0.1	uipp	
Tx jitter(20k-80MHz)				0.3	uipp	
Optical modulation amplitude	OM A	-6.2			dBm	
Dispersion penalty				1	dB	
Output Optical Eye	Compliant with IEEE 0802.3ae					
Receiver						
Operating Wavelength		1260		1610	nm	
Sensitivity	Pse n			-15	dBm	3
Min. overload	Pim ax	0,5			dBm	
LOS Assert	Pa	-30			dBm	
LOS De-assert	Pd			-16	dBm	
LOS Hysteresis	Pd- Pa	0.5		4	dB	

Note 1) Measured at 10.3125b/s with PRBS 231 – 1 NRZ test pattern.

Note 2) 20%~80%

Note 3) Under the ER worst case, measured at 10.3125 Gb/s with PRBS 231 - 1 NRZ test pattern for BER < 1x10-12

Pin Definitions and Functions

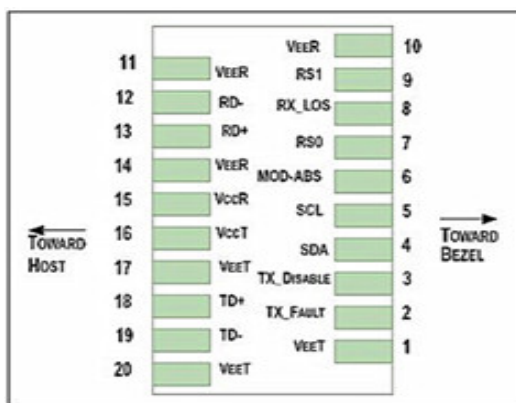
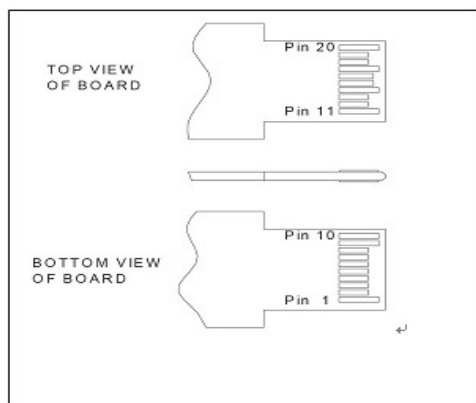

Pin	Symbol	Name/Description
1	VEET [1]	Transmitter Ground
2	Tx_FAULT [2]	Transmitter Fault
3	Tx_DIS [3]	Transmitter Disable. Laser output disabled on high or open
4	SDA [2]	2-wire Serial Interface Data Line
5	SCL [2]	2-wire Serial Interface Clock Line
6	MOD_ABS [4]	Module Absent. Grounded within the module
7	RS0 [5]	Rate Select 0
8	RX_LOS [2]	Loss of Signal indication. Logic 0 indicates normal operation
9	RS1 [5]	Rate Select 1
10	VEER [1]	Receiver Ground
11	VEER [1]	Receiver Ground
12	RD-	Receiver Inverted DATA out. AC Coupled
13	RD+	Receiver DATA out. AC Coupled
14	VEER [1]	Receiver Ground
15	VCCR	Receiver Power Supply
16	VCCT	Transmitter Power Supply
17	VEET [1]	Transmitter Ground
18	TD+	Transmitter DATA in. AC Coupled
19	TD-	Transmitter Inverted DATA in. AC Coupled
20	VEET [1]	Transmitter Ground

Notes: [1] Module circuit ground is isolated from module chassis ground within the module.
 [2].should be pulled up with 4.7k – 10k ohms on host board to a voltage between 3.15V and 3.6V.
 [3]Tx_Disable is an input contact with a 4.7 kΩ to 10 kΩ pullup to VccT inside the module.
 [4]Mod_ABS is connected to VeeT or VeeR in the SFP+ module. The host may pull this contact up to Vcc_Host with a resistor in the range 4.7 kΩ to 10 kΩ. Mod_ABS is asserted “High” when the SFP+ module is physically absent from a host slot.
 [5] RS0 and RS1 are module inputs and are pulled low to VeeT with > 30 kΩ resistors in the module.

Typical Interface Circuit

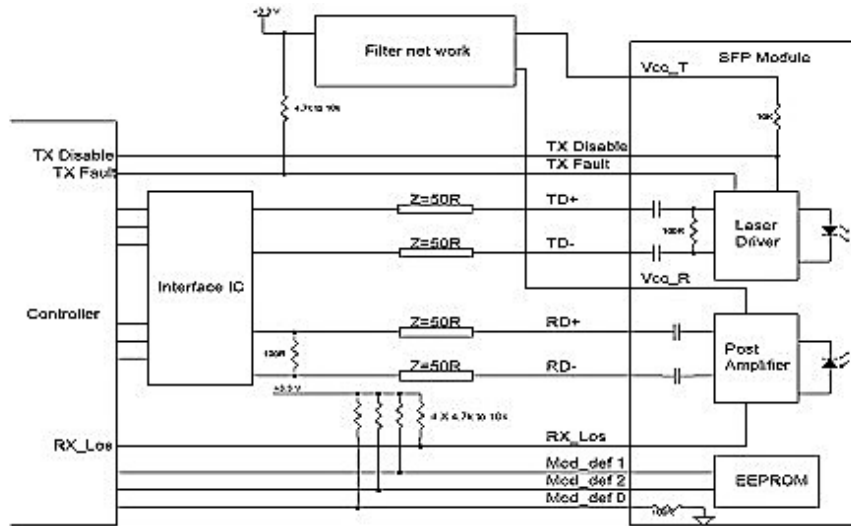

Recommended power supply filter

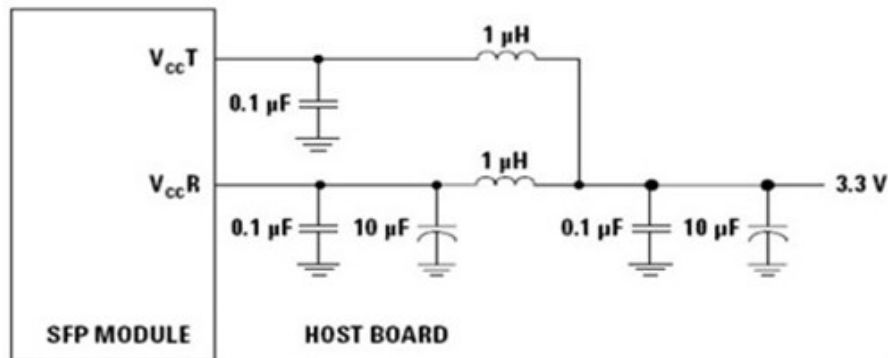

Note: Inductors with DC resistance of less than 1Ω should be used in order to maintain the required voltage at the SFP input pin with 3.3V supply voltage. When the recommended supply filtering network is used, hot plugging of the SFP transceiver module will result in an inrush current of no more than 30 mA greater than the steady state value.

Functional Diagram

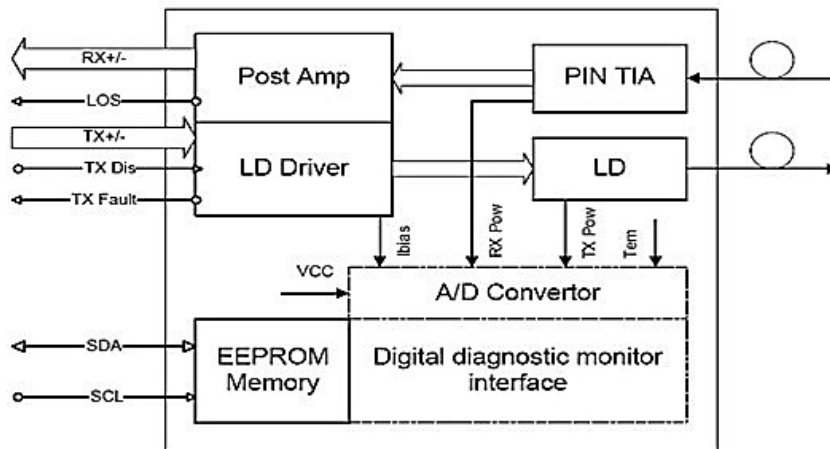

Package Dimensions

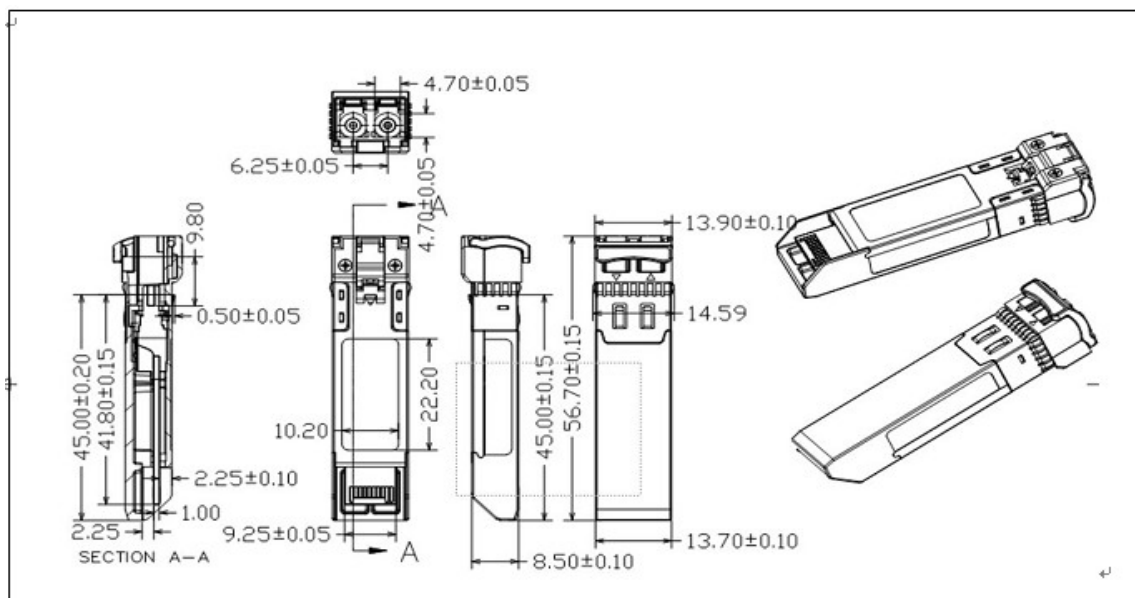

Ordering Information

Part Number	Output Power	Rec. Sens	Data Rate	Wavelength	Distance
SFP+-10G-LR	-6 ~0 db	-15db	10G	1310nm	20KM