

Applications

- 10GBASE-LR at 10.3125Gbps
- 10GBASE-LW at 9.953Gbps
- 10GBASE-BX 10G Ethernet



Product Features

- Supports 9.95Gbps to 11.1Gbps bit rates
- Maximum link length of 40km with SMF
- TX1270(1330)nm DFB laser Transmitter and RX1330(1270) nm PIN Receiver
- XFP MSA package with duplex LC connector
- Very low EMI and excellent ESD protection
- Hot-pluggable XFP footprint
- +3.3V single power supply
- Temperature range 0°C to 70°C

General

XFP-BIDI-12-40D - is compliant with the IEEE803.3ae 10Gbase-Bx. and transmission distance up to 40km on SMF.

The transceiver module comprises a transmitter with a 1270(1330) nm DFB laser transmitter, an integrated 1330(1270) nm detector preamplifier (IDP) mounted in an optical header and a limiting post-amplifier IC. Transmitter and receiver are separate within a wide temperature range of 0°C to +70°C and offers optimum heat dissipation and excellent electromagnetic shielding thus enabling high Page 2 of 9 Feb 27/2013 port densities for 10 GbE systems.

Absolute Maximum Ratings

Parameter	Symbol	Min.	Max.	Unit	Note
Supply Voltage	Vcc	-0.5	4.0	V	
Storage Temperature	Ts	-40	85	°C	
Relative Humidity	RH	0	85	%	

Note: Stress in excess of the maximum absolute ratings can cause permanent damage to the module

General Operating Characteristics

Parameter		Symbol	Min.	Typ	Max.	Unit	Note
Data Rate	Ethernet			10.3125		Gb/s	
	Fiber Channel			10.518			
Supply Voltage		V _{cc}	3.13	3.3	3.47	V	
		V _{cc}				V	
Supply Current		I _{cc5}				mA	
		I _{cc3}			500	mA	
Operating Case Temp.		T _c	0		70	°C	

Electrical Input/Output Characteristics

Parameter		Symbol	Min.	Typ	Max.	Unit	Note
Transmitter							
Diff. input voltage swing			120		820	mVpp	1
Tx Disable input	H	V _{IH}	2.0		V _{cc} +0.3	V	
	L	V _{IL}	0		0.8		
Tx Fault output	H	V _{OH}	2.0		V _{cc} +0.3	V	2
	L	V _{OL}	0		0.8		
Input Diff. Impedance		Z _{in}		100		Ω	
Receiver							
Diff. output voltage swing			340	650	800	mVpp	3
Rx LOS Output	H	V _{OH}	2.0		V _{cc} +0.3	V	2
	L	V _{OL}	0		0.8		

Notes:

1. TD+/- are internally AC coupled with 100Ω differential termination inside the module.
2. Tx Fault and Rx LOS are open collector outputs, which should be pulled up with 4.7k to 10kΩ resistors on the host board. Pull up voltage between 2.0V and V_{cc}+0.3V.
3. RD+/- outputs are internally AC coupled, and should be terminated with 100Ω (differential) at the user SERDES.

Optical Characteristics

Parameter	Symbol	Min.	Typ	Max.	Unit	Note
Transmitter						
Operating Wavelength		1260 (1320)	1270 (1330)	1280 (1340)	nm	
Ave. output power (Enabled)	Po	0		5	dBm	1
Extinction Ratio	ER	5			dB	1
RMS spectral width	$\Delta\lambda$			0.45	nm	
Rise/Fall time (20%~80%)	Tr/Tf			45	ps	2
Optical modulation amplitude	OMA			-2.8	dBm	
Dispersion penalty				3.9	dB	
Output Optical Eye	Compliant with IEEE 0802.3ae					
Receiver						
Operating Wavelength		1320 (1260)	1330 (1270)	1340 (1280)	nm	
Sensitivity	Psen			-15	dBm	3
Min. overload	Pimax	0.5			dBm	
LOS Assert	Pa	-25			dBm	
LOS De-assert	Pd			-16	dBm	
LOS Hysteresis	Pd-Pa	0.5		4	dB	

Notes:

1. Measured at 10.3125b/s with PRBS 2³¹ – 1 NRZ test pattern.
2. 20%~80%
3. Under the ER worst case, measured at 10.3125 Gb/s with PRBS 231 - 1 NRZ test pattern for BER < 1x10⁻¹²
4. If there is DWDM Product ,the wavelength XX— CH 17-61

Pin Definitions and Functions

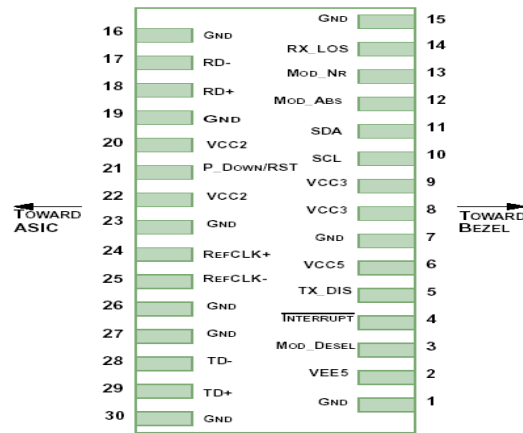

PIN	Name	Function	Name/Description	Notes
1		GND	Module Ground	1
2		VEE5	Optional -5.2V Power Supply (Not required)	
3	LVTTL-I	MOD_DESEL	Module De-select; When held low allows the module to respond to 2-wire serial interface	
4	LVTTL-O	INTb	Interrupt; Indicates presence of an important condition which can be read via the 2-wire serial interface	2
5	LVTTL-I	TX_DIS	Transmitter Disable; Turns off transmitter laser output	
6		VCC5	+5V Power Supply (Not required)	
7		GND	Module Ground	1
8		VCC3	+3.3V Power Supply	
9		VCC3	+3.3V Power Supply	
10	LVTTL-I/O	SCL	2-Wire Serial Interface Clock	2
11	LVTTL-I/O	SDA	2-Wire Serial Interface Data Line	2
12	LVTTL-O	MOD_Abs	Indicates Module is not present. Grounded in the Module	2
13	LVTTL-O	MOD_NR	Module Not Ready; Indicating Module Operational Fault	2
14	LVTTL-O	RX_LOS	Receiver Loss Of Signal Indicator	2
15		GND	Module Ground	1
16		GND	Module Ground	1
17	CML-O	RDN	Receiver Inverted Data Output	
18	CML-O	RDP	Receiver Non-Inverted Data Output	
19		GND	Module Ground	1
20		VCC2	+1.8V Power Supply (Not required).	
21	LVTTL-I	P_DOWN/RST	Power down; When high, requires the module to limit power consumption to 1.5W or below. 2-Wire serial interface must be functional in the low power mode.	
21	LVTTL-I	P_DOWN/RST	Reset; The falling edge initiates a complete reset of the module including the 2-wire serial interface, equivalent to a power cycle.	
22		VCC2	+1.8V Power Supply (Not required)	
23		GND	Module Ground	1
24	PECL-I	REFCLKP	Not used, internally terminated to 50ohm (100ohm diff).	3
25	PECL-I	REFCLKN	Not used, internally terminated to 50ohm (100ohm diff).	3
26		GND	Module Ground	1
27		GND	Module Ground	1

28	CML-I	TDN	Transmitter Inverted Data Input	
29	CML-I	TDP	Transmitter Non-Inverted Data Input	
30		GND	Module Ground	1

Notes:

1. Module circuit ground is isolated from module chassis ground within the module.
2. Open collector; should be pulled up with 4.7k – 10k ohms on host board to a voltage between 3.15V and 3.6V.
3. Reference Clock input is not required.

Management Interface

The transceivers provide serial ID memory contents and diagnostic information about the present operating conditions by the 2-wire serial interface (SCL, SDA).

The Module provides diagnostic information about the present operating conditions. The transceiver generates this diagnostic data by digitization of internal analog signals Alarm/warning threshold data is written during device manufacture. Received power monitoring, transmitted power monitoring, bias current monitoring, supply voltage monitoring and temperature monitoring all are implemented.

The digital diagnostic memory map specific data field defines as following.

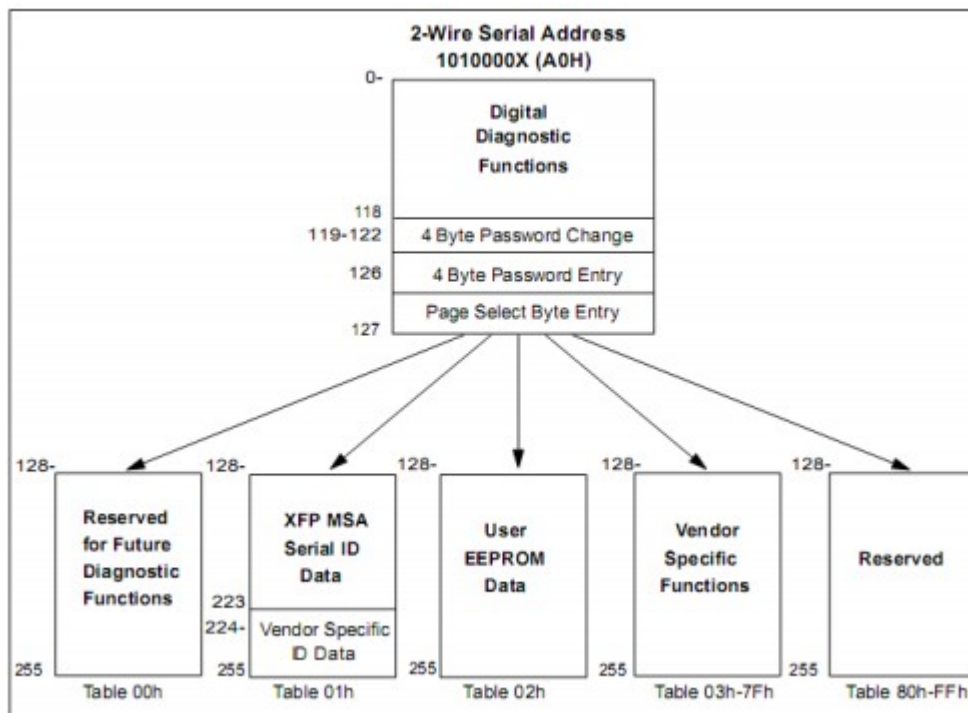

Typical Interface Circuit

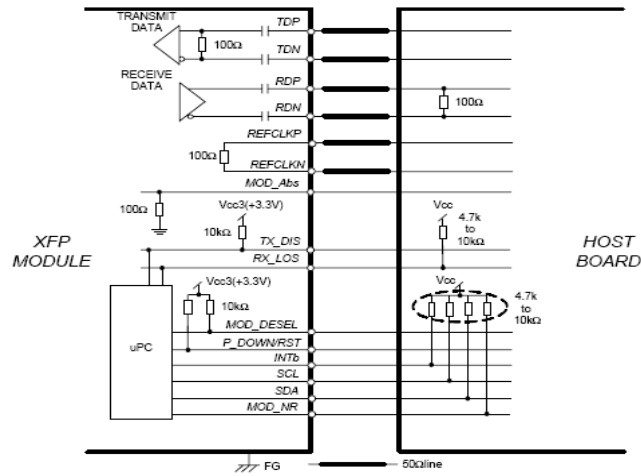

Package Dimensions

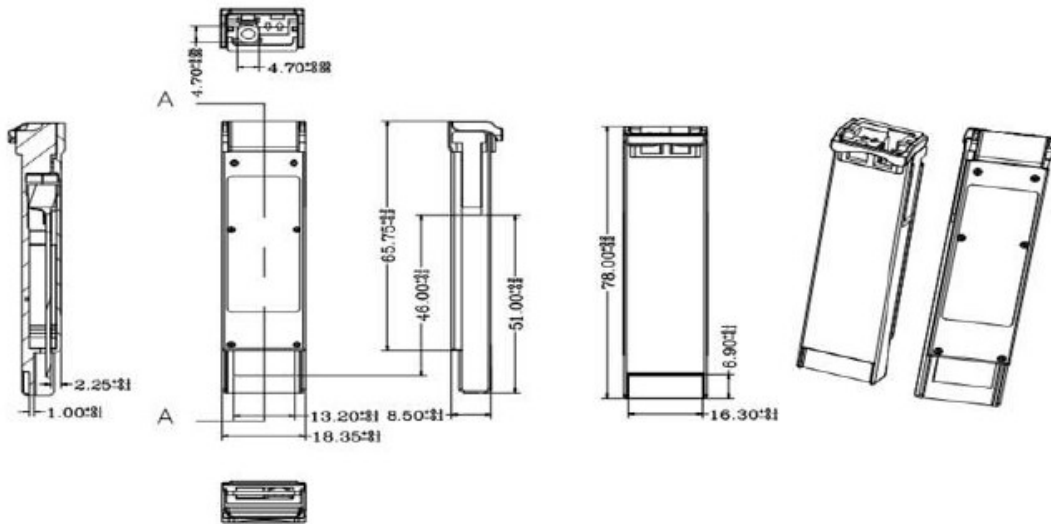

Ordering Information

Part Number	Output Power	Rec. Sens	Data Rate	Wavelength	Distance
XFP-BIDI-12-40D	0 ~ 5 db	-15 db	9.95G~11.1G	TX1270/RX1330nm	40km
XFP-BIDI-13-40D	0 ~ 5 db	-15 db	9.95G~11.1G	TX1270/RX1330nm	40km