

GPON OLT C+++ Optical Module



Product Features

- Support ITU-T G.984.2 GPON OLT C+++ application
- Single fiber bi-directional data links with symmetric 2.488Gbps Tx and 1.244Gbps Rx
- 1490nm continuous-mode transmitter with DFB LD
- 1310nm burst-mode receiver with APD-TIA
- 2-wire interface for integrated digital diagnostic Monitoring
- Receiver RESET, Signal Detect, RSSI function indication (RESET, RX_SD, RSSI)
- SFP package with SC/UPC receptacle optical interface
- Single +3.3V power supply
- Operating case temperature: 0~70°C
- RoHS6 compliance

Operating Condition

Parameter	Unit	Min.	Typical	Max.
Storage Temperature	°C	-40		85
Operating Case Temp for C-temp	°C	0		70
Power Supply Voltage	V	3.15	3.3	3.45
Supply Current	mA			500
Bit Rate for Tx	Gbps		2.488	
Bit Rate for Rx	Gbps		1.244	

Characteristics

All performance is specified at whole working temperature and conditions

Parameter	Unit	Min.	Typical	Max.
Transmitter				
TX Central Wavelength	nm	1480	1490	1550
Spectral Width (-20dB)	nm			1
Side Mode Suppression Ratio (SMSR)	dB	30		
Mean Launched Power	dBm	7		10
Mean Launched Power (TX Off)	dBm			-45
Extinction Ratio	dB	8.2		
Optical Return Loss Tolerance	dB	-15		
Transmitter and dispersion Penalty	dB			1
Transmitter Mask(PRBS2 ²³ -1@2.488G)	Compliant With ITU-T G.984.2			
Receiver				
Receive Wavelength	nm	1290	1310	1330

Sensitivity (PRBS ²³ -1@1.244G,ER=10,BER<10 ⁻¹⁰)	dBm			-30
Overload (PRBS ²³ -1@1.244G,ER=10,BER<10 ⁻¹⁰)	dBm	-12		
Receiver Burst Mode Dynamic Range	dB	15		
Damage Threshold for Receiver	dBm	5		
SD Assert Level	dBm			-33
SD De-assert Level	dBm	-45		
SD Hysteresis	dB	0.5		6
WDM Filter isolation to 1550nm	dB	38		
WDM Filter isolation to 1650nm	dB	35		
Electrical Interface Characteristics				
Data Input Swing Differential/TX	mV	200	-	2000
Data Output Swing Differential/RX	mV	400		1600
Date Differential Impedance	Ω	90	100	110
LVTTL Output High	V	2.4		Vcc
LVTTL Output Low	V	0		0.4
LVTTL Input High	V	2.0		Vcc+0.3
LVTTL Input Low	V	0		0.8
Timing Characteristics				
Guard Time (Tg)	ns	25.6		
Reset Pulse Width (Tr)	ns			12.8
Reset Delay (Trd)	ns			12.8
Receiver Preamble Time (Tp)	ns			140
SD Assert Time (TSDA)	ns			100
SD De-assert Time (TSDD)	ns			12.8
RSSI Trigger Delay (Ttd)	ns	25		
RSSI Trigger Pulse Width (Tw)	ns	500		
Internal I2C Delay (TI2C)	us			500

Timing Sequence for RSSI

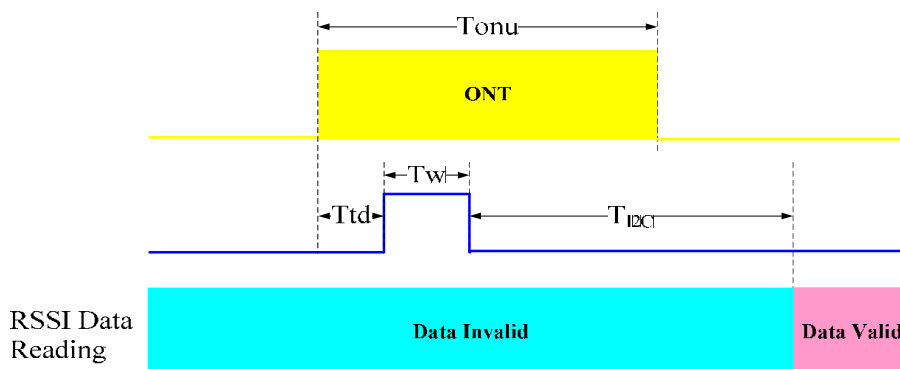

Timing Sequence for Ranging Mode

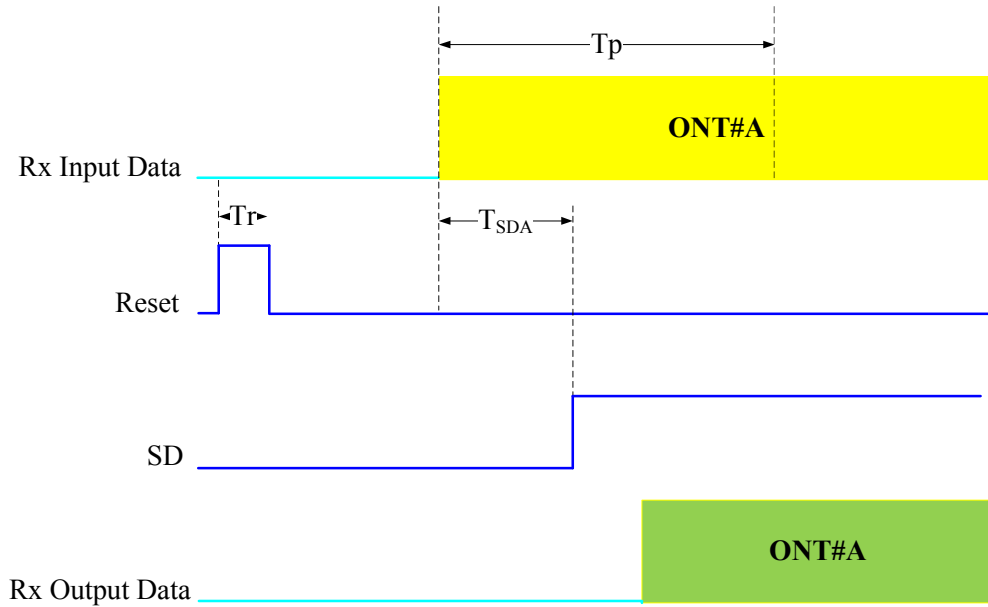

Timing Sequence for Working Mode

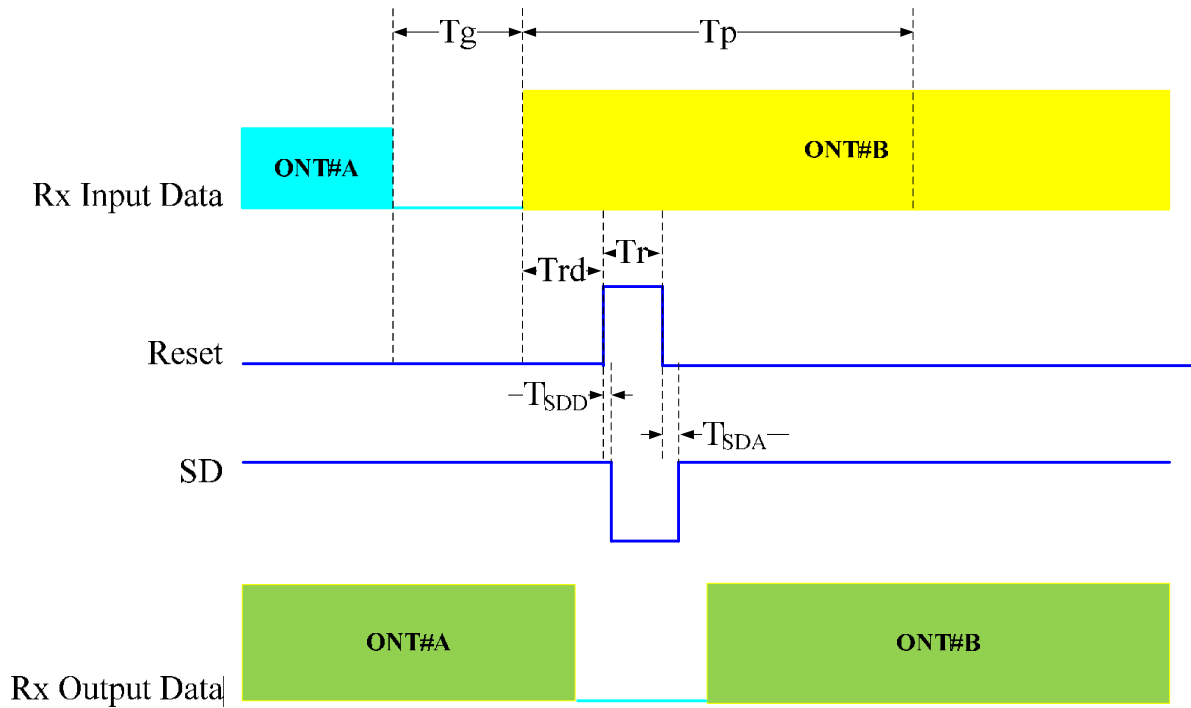

Pin Definitions

Pin No.	Symbol	Level / Logic	Description
1	VeeT		Module Transmitter Ground
2	Tx_Fault	LVTTL-O	Module Transmitter Fault
3	Tx_DIS	LVTTL-I	Laser output is disabled when this pin is asserted high or left unconnected
4	SDA	LVTTL-I	2-Wire Serial Interface Data Line
5	SCL	LVTTL-I/O	2-Wire Serial Interface Clock
6	MOD_ABS	LVTTL-O	Module Absent, connected to ground in the module
7	RX_Reset	LVTTL-I	Receiver RESET signal
8	RX_SD	LVTTL-O	Receiver Signal Detected Indication
9	RSSI_TRIG	LVTTL-I	Receiver RSSI Trigger signal
10	VeeR		Module Receiver Ground
11	VeeR		Module Receiver Ground
12	RD-	LVPECL-O	Receiver Inverted Data Output
13	RD+	LVPECL-O	Receiver Non-Inverted Data Output
14	VeeR		Module Receiver Ground
15	VccR		Module Receiver 3.3V Supply
16	VccT		Module Transmitter 3.3V Supply
17	VeeT		Module Transmitter Ground
18	TD+	LVPECL-I	Transmitter Non-Inverted Data Input
19	TD-	LVPECL-I	Transmitter Inverted Data Input
20	VeeT		Module Transmitter Ground

Recommended Interface Circuit

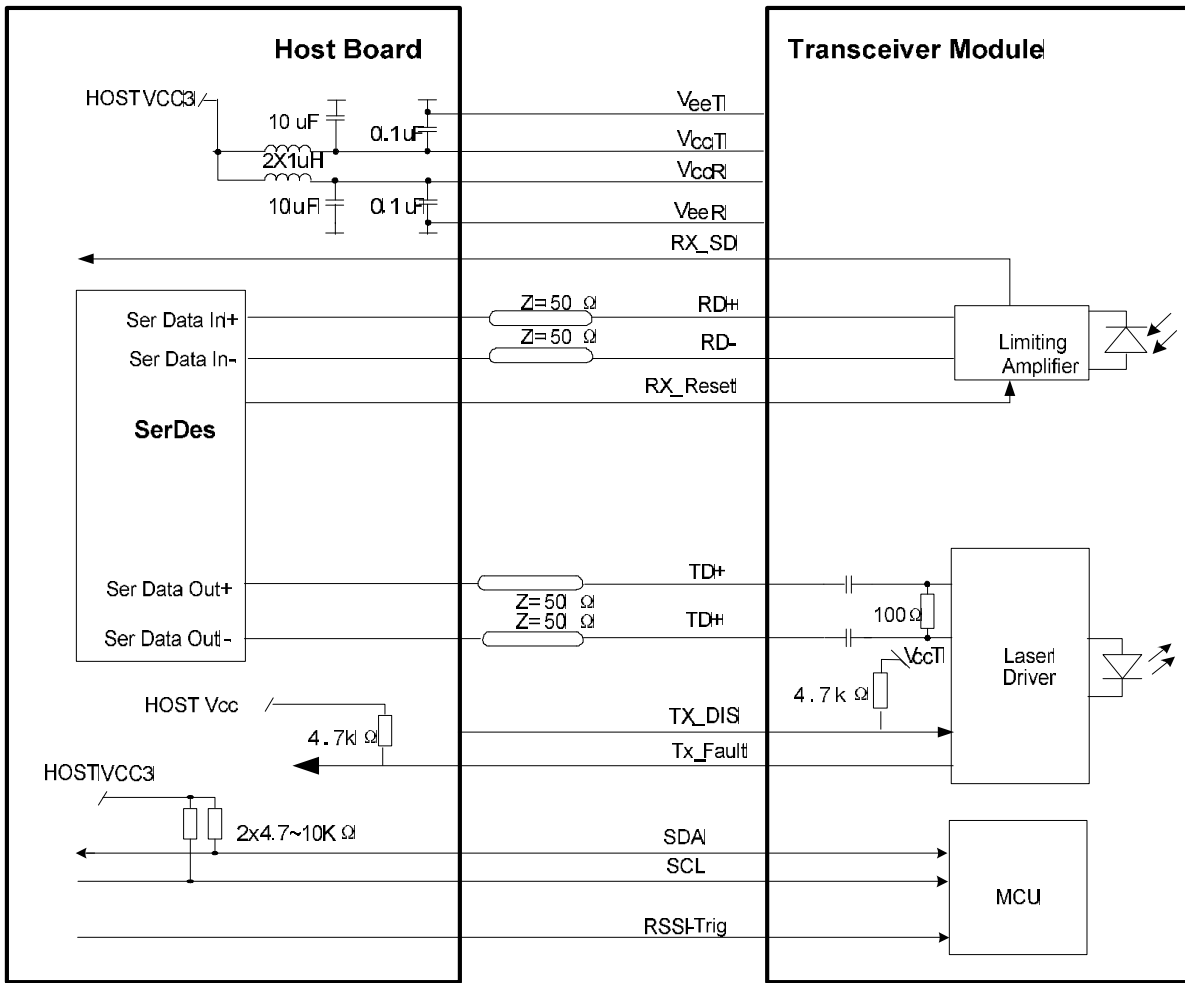

Mechanical Diagram

EEPROM Memory Map – Page A0h

Addr.(Dec)	Size(byte)	Name of field	Default Value(Hex)	Description
0	1	Identifier	03	Pluggable transceiver
1	1	Extended Identifier	04	Function defined by serial ID
2	1	Connector	01	SC Receptacle
3	8	Transceiver	00,00,00,00, 00,00,00,00	Not Supported
11	1	Encoding	03	NRZ encoding
12	1	Nominal Bit Rate in 100Mbps	19	2488.32 Mbps
13	1	Reserved	0	Reserved
14	1	Length (9μ,km) in km	14	20km
15	1	Length (9μ,m) in 100m	C8	20km
16	1	Length (50μ) in 10m	00	Not Supported
17	1	Length (62.5μ) in 10m	00	Not Supported
18	1	Length (Copper) in m	00	Not Supported
19	1	Reserved	00	Reserved
20	16	Vendor Name (ASCII)	XX	Vendor Name (ASCII)
36	1	Reserved	00	Reserved
37	3	Vender IEEE Company ID	00,00,00	IEEE ID
40	16	Vendor Part Number (ASCII)	XX	Vendor Part Number (ASCII)
56	4	Vendor Rev (ASCII)	31,20,20,20	Revision
60	2	Laser Wavelength in nm	05,D2	1490nm Tx Wavelength
62	1	Reserved	00	Reserved
63	1	Check Code for Base ID Fields	XX	Checksum from byte 0-62
64	2	Options	00,1C	TX_DIS, TX_Fault, SD
66	1	Upper Bit Rate Margin in %	00	Not specified
67	1	Lower Bit Rate Margin in %	00	Not specified
68	16	Vendor Serial Number(ASCII)	XX	Serial number field (ASCII)
84	8	Date Code	XX	YYMMDD0000
92	1	Diagnostic Monitoring Type	68	Internal Calibration, Average Power Measurement
93	1	Enhanced Options	E0	Optical Alarm/warning implemented Soft Tx_Dis, Tx_Fault implemented
94	1	SFF - 8472 Compliance	02	Compliance to SFF - 8472 Rev 9.5
95	1	Check Code for Extended ID Fields	XX	Checksum from byte 64-69

96	32	Vendor Specific	FF...FF	Vendor Specific
128	128	Reserved	FF...FF	Reserved; return to FF

EEPROM Memory Map – Page A2h

Addr.(Dec)	Size(byte)	Name of field	Default Value(Hex)	Description
0	2	Temp High Alarm	55,00	85C
2	2	Temp Low Alarm	F1,00	-15C
4	2	Temp High Warning	50,00	80C
6	2	Temp Low Warning	F6,00	-10C
8	2	Voltage High Alarm	8C,A0	3.6V
10	2	Voltage Low Alarm	75,30	3.0V
12	2	Voltage High Warning	88,B8	3.5V
14	2	Voltage Low Warning	79,18	3.1V
16	2	Bias High Alarm	B9,8C	95mA
18	2	Bias Low Alarm	03,E8	2mA
20	2	Bias High Warning	A6,04	85mA
22	2	Bias Low Warning	05,DC	3mA
24	2	TX Power High Alarm	FF,FE	+8.16 dBm
26	2	TX Power Low Alarm	3D, E8	+2dBm
28	2	TX Power High Warning	FF,FE	+8.16dBm
30	2	TX Power Low Warning	4D, F0	+3.0dBm
32	2	RX Power High Alarm	07,CB	-7dBm
34	2	RX Power Low Alarm	00,05	-33dBm
36	2	RX Power High Warning	06,31	-8dBm
38	2	RX Power Low Warning	00,06	-32dBm
40	16	Reserved	00...00	Reserved
56	4	RX_PWR(4) Calibration	00,00	4th order RSSI calibration coefficient
60	4	RX_PWR(3) Calibration	00,00	3rd order RSSI calibration coefficient
64	4	RX_PWR(2) Calibration	00,00	2nd order RSSI calibration coefficient
68	4	RX_PWR(1) Calibration	3F,80	1st order RSSI calibration coefficient
72	4	RX_PWR(0) Calibration	00,00	0th order RSSI calibration coefficient
76	2	TX_I(Slope) Calibration	01,00	Slope for Bias calibration
78	2	TX_I(Offset) Calibration	00,00	Offset for Bias calibration
80	2	TX_PWR(Slope) Calibration	01,00	Slope for TX Power calibration
82	2	TX_PWR(Offset) Calibration	00,00	Offset for TX Power calibration
84	2	T(Slope) Calibration	01,00	Slope for Temperature calibration

86	2	T(Offset) Calibration	00,00	Offset for Temperature calibration, in units of 256ths C
88	2	V(Slope) Calibration	01,00	Slope for VCC calibration
90	2	V(Offset) Calibration	00,00	Offset for VCC calibration
92	3	Reserved	00,00,00	Reserved
95	1	Checksum	XX	Checksum
96	2	Transceiver Temperature	XX	Temperature in C/256
98	2	Supply Voltage	XX	Vcc
100	2	TX Bias Current	XX	BIASMON
102	2	TX Optical Output Power	XX	Back facet monitor
104	2	RX Optical Input Power	XX	RSSI
106	2	Reserved	00,00	Reserved
108	2	Reserved	00,00	Reserved
110.7	1bit	TX_DIS State	X	Digital state of the TX Disable InputPin.
110.6	1bit	Soft TX Disable Select	X	Read/write bit that allows software disable of laser.
110.5	1bit	Reserved.	0	Reserved.
110.4	1bit	Rate Select State	0	NOT SUPPORTED.
110.3	1bit	Soft Rate_Select Select	0	NOT SUPPORTED.
110.2	1bit	TX Fault State	X	Digital state of the TX Fault Output Pin.
110.1	1bit	Rx_LOS State	0	Digital state of the LOS Output Pin.
110.0	1bit	Data_Ready_Bar State	X	Indicates transceiver has achieved power up and data is ready.
111	1	Reserved	00	Reserved
112	1	Alarm and Warning Flag Bits	XX	Refer to SFF-8472 Table 3.18
113	1	Alarm and Warning Flag Bits	XX	Refer to SFF-8472 Table 3.18
114	1	Reserved	00	Reserved
115	1	Reserved	00	Reserved
116	1	Alarm and Warning Flag Bits	XX	Refer to SFF-8472 Table 3.18
117	1	Alarm and Warning Flag Bits	XX	Refer to SFF-8472 Table 3.18
118	1	Reserved	00	Interrupt Mask for ISRC2
119	1	Reserved	00	Interrupt Mask for ISRC3
120	8	Vendor Specific	00...00	Vendor specific memory addresses
128	128	Reserved	FF...FF	Reserved; return to FF